

TOP VIEW

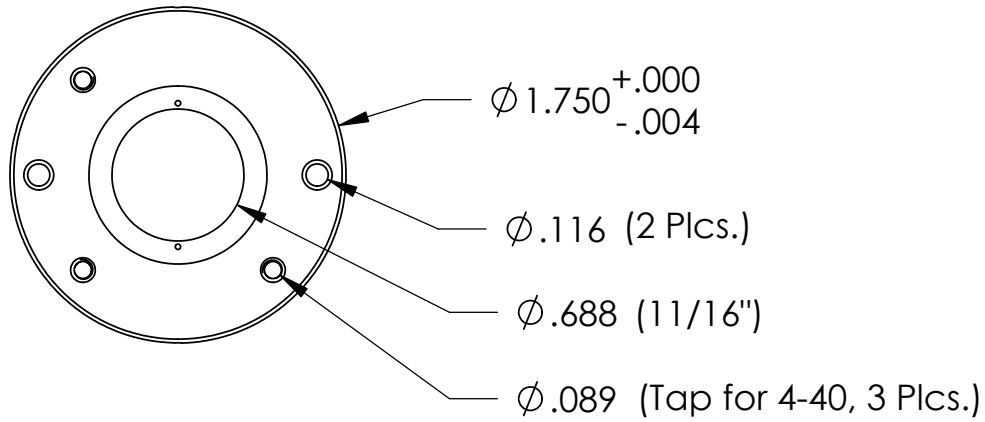

BOTTOM VIEW

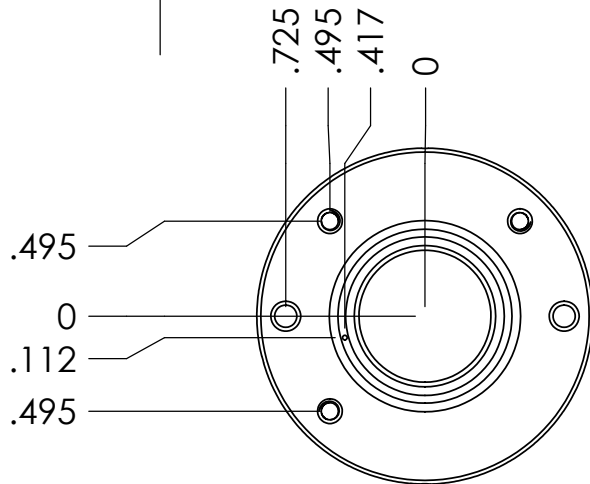

PROPRIETARY AND CONFIDENTIAL
 THE INFORMATION CONTAINED IN THIS DRAWING IS THE SOLE PROPERTY OF C&L INSTRUMENTS, INC. ANY REPRODUCTION IN PART OR AS A WHOLE WITHOUT THE WRITTEN PERMISSION OF C&L INSTRUMENTS, INC. IS STRICTLY PROHIBITED.

		PROPERTY OF C&L INSTRUMENTS		NAME	DATE	TITLE: VC-MPC-OT Customer Drawing				
		DIMENSIONS ARE IN INCHES	DRAWN					SIZE A	DWG. NO.	REV
		TOLERANCES: TWO PLACE DECIMAL ± 0.01 THREE PLACE DECIMAL ± 0.002 UNLESS STATED OTHERWISE	CHECKED							
		INTERPRET GEOMETRIC TOLERANCING PER:	ENG APPR.							
		MATERIAL 6061 Aluminum FINISH Black Anodize	COMMENTS:							
	NEXT ASSY	USED ON								
	APPLICATION		DO NOT SCALE DRAWING							